



# **SF10**

# **SUBWOOFER**

*Installation & Operation Manual*

## Introduction

Congratulations on your purchase of an Destination Audio SF10 Powered Subwoofer! Your subwoofer is the result of many years of research and development dedicated to producing powerful, accurate bass in home audio and video systems. This manual contains operating procedures and specifications. We recommend you thoroughly read through the material contained in this manual before connecting your subwoofer. This will ensure you have an understanding of how to setup and operate your subwoofer for optimum performance.

## SF10 Subwoofer

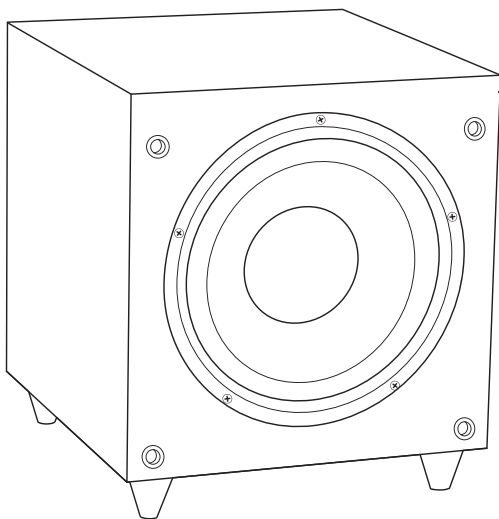

## Break In Period

Allow 10-15 hours of listening time to adequately break-in the SF10 Subwoofer. During the break-in period, the driver suspension will loosen. The result of break-in will be an increase in low frequency response, improved definition, and increased clarity and detail.

## Care and Cleaning

To maintain speaker appearance, we recommend an occasional application of furniture grade polish to the wood surface of the cabinet. To clean dust from the grille cloth, use a vacuum with a brush attachment.

## Features

A powered subwoofer is a must-have component for any home theater or audio system. The performance of your subwoofer can greatly affect the overall performance of your system. Without the powered subwoofer, the deep bass on your music CDs and special effects on DVDs may not be heard and/or felt. Think of a subwoofer as a vital component that adds excitement to your theater or music experience. The powered subwoofer has its own source of amplification (as opposed to passive, non-amplified subwoofers which require an additional power amplifier). Subwoofers can add considerable low-frequency, deep bass performance to any home theater or audio system.

At the heart of the Destination Audio SF10 powered subwoofer is a aluminized fiberglass matrix cone driver. The driver material produces enhanced bass definition and accuracy. A powerful magnet, enhanced suspension and heavy duty voice coil give the driver elevated performance allowing high output capability and accurate dynamic reproduction.

The SF10 powered subwoofer incorporates a discrete class A/B analog power supply amplifier ensuring low distortion, high current output and proven reliability. Variable crossover, adjustable phase control and auto on/off are also used for convenience and easy integration with other speakers. Connectivity is made easy by allowing the subwoofer to be connected by either interconnect (processor/line level) or speaker wire (high level).

Cabinets are constructed from medium density fiberboard because of its inert properties. The thickness of the front baffles also prevents excess acoustic radiation. Large oversized gold binding posts ensure a good electrical contact. Sophisticated computer modeling and measurement techniques are used extensively in the Destination Audio subwoofer design process.

## Setup Suggestions

Placement of the subwoofer will largely determine quality, quantity and extension of the bass frequencies within your listening room. Bass frequencies are reinforced by close room boundaries. Placing the subwoofer in a corner will make the subwoofer sound louder and boost the very lowest frequencies.

## Setup Suggestions (continued)

Placing the subwoofer away from walls will provide the least reinforcement, making the bass sound subjectively thinner than if the woofer were closer to a wall. Good results can usually be obtained by placing a subwoofer along a wall 1-3 feet from a corner. Experiment with placement of the subwoofer and the sub-amplifier controls to achieve the proper bass balance.

It is important the signal being sent to the subwoofer be a non-boosted or "flat" signal. To be sure of this, check the settings on your receiver or processor to determine any "bass boost", "super bass" or "loudness" is set to Off. In most cases for home theater setting a receiver or processor will determine the crossover frequency through bass management settings. In this configuration connect the receiver or processor to the LFE Line Level Input. Your subwoofer can now reproduce the bass frequencies the way they were originally recorded. Use the subwoofer level control and the individual bass management control within the receiver or processor to adjust the subwoofers volume if necessary. Once set, the volume controls should not need to be altered as the subwoofers volume will coincide with the master volume control of your receiver or processor.

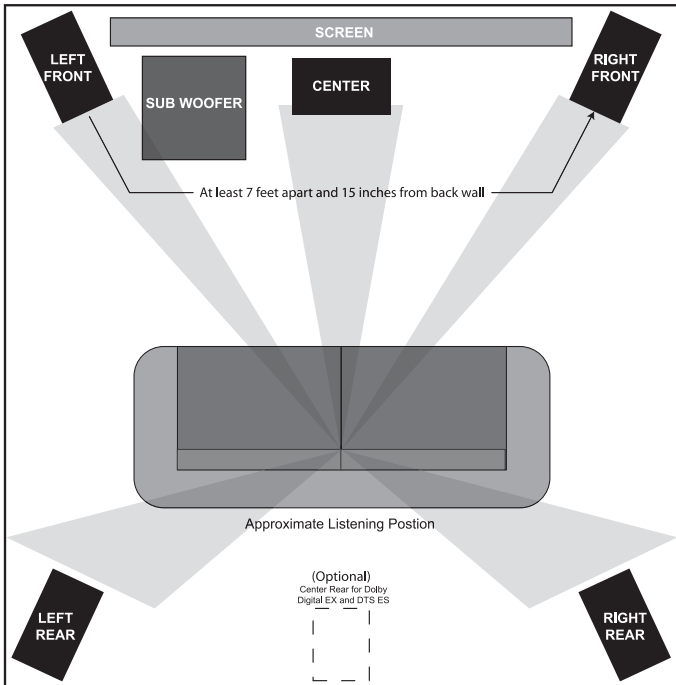

# Amplifier Controls and Setup

1. **Volume Control:** The volume control should be at the minimum setting (all the way counter clockwise) before plugging the subwoofer into a 120V AC wall socket.

2. **Crossover Frequency Control:** The variable crossover frequency control allows you to set the crossover point of the subwoofer anywhere from 50-150 Hz. This control is only active with use of the left and right line level inputs (#5). If using these inputs experiment with setting the crossover frequency control at highest setting initially. Increasing the crossover frequency will allow more mid-bass output from the subwoofer. Decreasing the frequency will cut more mid-bass output from the subwoofer.

3. **Phase Control:** This control changes the phase of the subwoofer. Changing the phase will change the way the subwoofer and main speakers interact with each other at the crossover frequency. Varying the phase position may result in more or less mid-bass depending on the phasing between the main speakers and the subwoofer. Generally, the phase is left at the 0° position.

4. **LFE Line Level Input:** Typically this will be the line level input used to connect to most receivers or processors. The LFE input will bypass the subwoofers crossover control, rendering it non-functioning. This input should be used when the input signal is coming from a receiver or processor where the bass management is controlled by the receiver or processor.

5. **L/R Line Level Input:** If a full-range signal is being sent from the receiver or processor then these inputs should be used. In this configuration the crossover frequency (#2) is active.

6. **High Level Input:** These binding post terminal connectors are for the amplifier/speaker level input from an amplifier or receiver. Usually, the LFE line level input (#4) will be used. Important! Use either the Line Input or the High Level Input. DO NOT use them both simultaneously.

7. **High Level/Speaker Output:** This is a 100 Hz high pass crossover for your satellite/main speakers. The crossover limits the low frequencies (below 100 Hz) from going to your satellite/main speakers. You may use this crossover only when using the High Level Input terminals. Connect your main speakers (observing the proper polarity) to the terminals labeled "High Level Out".



Back View of SF10 Subwoofer

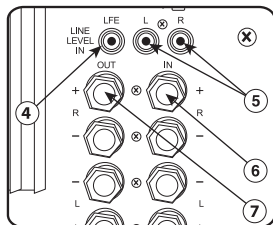
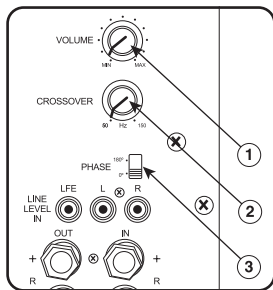

# Specifications

<b>Model:</b>	<b>SF10</b>
<b>Frequency Response:</b>	30Hz-150Hz $\pm$ 3dB
<b>Amplifier Power:</b>	100 Watts
<b>Woofer:</b>	10" Aluminized Fiberglass Matrix
<b>Crossover Frequencies:</b>	50-150Hz
<b>Dimensions:</b>	13"H x 14½"W x 16"D
<b>Weight:</b>	27 lbs.

# Troubleshooting

<b>Situation:</b>	<b>Probable Cause:</b>	<b>Solution:</b>
<b>No sound from subwoofer(s)</b>	Amplifier is not connected to constant power outlet.	Make certain the amplifier is plugged into an unswitchable A.C. power outlet.
	Amplifier is not receiving an audio signal from receiver or processor	Make certain there is an audio signal from receiver or processor and audio connections resemble those in the connections section of this manual.
	Amplifier fuse might be blown.	Replace fuse (if fuse is not readily accessible, consult your authorized RBH dealer).
<b>Performance is less than expected</b>	The + and - polarity of the subwoofer wire might be reversed on the subwoofer.	Check the entire system for proper polarity. Experiment with the phase switch.
	Crossover frequency not adjusted correctly.	Adjust crossover frequency by turning the crossover frequency control clockwise until desired sound is obtained.
	L/R line level input is connected instead of the LFE line level input.	If bass management is enabled on receiver or processor make sure to use the LFE line level input. (See amplifier controls and setup on previous page.)

## Warranty

Your Destination Audio SF10 subwoofer is covered by a limited warranty against defects in materials and workmanship for a period of 5 (five) years on the woofer and cabinet, and 1 (one) year on the amplifier from the original date of purchase. This warranty is provided by the authorized Destination Audio dealer where the subwoofer was purchased. Warranty repair will be performed only when your purchase receipt is presented as proof of ownership and date of purchase. Defective parts will be repaired or replaced without charge by your dealer's store or the location designated by your dealer that is authorized to service Destination Audio products.

Charges for unauthorized service and transportation cost are not reimbursable under this warranty. This warranty becomes void if the product has been damaged by alteration, misuse or neglect. The warrantor assumes no liability for property damage or any other incidental or consequential damage whatsoever which may result from the failure of this product. Any and all warranties of merchantability and fitness implied by law are limited to the duration of this express warranty. Some states do not allow limitations on how long an implied warranty lasts, so the above limitations may not apply to you. Some states do not allow the exclusion or limitation of incidental or consequential damages, so the above limitation or exclusion may not apply to you.



*Audio Products That Complement Your Life.™*

382 Marshall Way, Layton, Utah • USA • 84041

Toll Free: (800) 543-2205 • Fax: (801) 543-3300

[www.destinationaudio.com](http://www.destinationaudio.com)